

ODYSSEY™

THE EXTREME BATTERY



A GUIDE TO THE ODYSSEY RANGE OF BATTERIES

ODYSSEY™

THE EXTREME BATTERY

THE ODYSSEY™ BATTERY INGENUOUSLY USES ABSORBED GLASS MAT (AGM) TECHNOLOGY TO OFFER, IN ONE BOX, THE CHARACTERISTICS OF TWO SEPARATE BATTERIES. IT CAN DEEP CYCLE AS WELL AS PROVIDE ENORMOUS CRANKING POWER - IT IS ALMOST AS IF A CHAMPION LONG DISTANCE RUNNER AND A WORLD CLASS SPRINTER ARE ONE AND THE SAME PERSON.

These batteries are capable of providing engine cranking pulses in excess of 2250A for 5 seconds as well as 400 charge/discharge cycles to 80% depth of discharge (DOD). A typical starting, lighting and ignition (SLI) battery can do one or the other, but not both. It is either a sprinter or a long distance runner; ODYSSEY batteries will do both — provide short duration high amperage pulse or low rate long duration drains.

GUARANTEED LONGER SERVICE LIFE

With an eight to twelve year design life (float) and a three to ten year service life, ODYSSEY saves you time and money because you do not have to replace the battery as often. ODYSSEY is warranted against factory defects for two full years in powersports or three full years in automotive, commercial and heavy-duty marine applications. Since actual warranty can vary with your geographical location, please check with your ODYSSEY representative for the warranty specific to your application.

SUPERIOR CRANKING AND FAST CHARGE CAPABILITY

The 5 second cranking power of ODYSSEY batteries is double to triple that of equally sized conventional batteries, even when the temperature is as low as -40°C (-40°F). Also, with simple constant voltage charging (alternator or independent charger), there is no limitation on the inrush current, so the user is assured of fast charge recovery.

MOUNTING FLEXIBILITY

The ODYSSEY battery may be installed in any orientation (except inverted) without sacrificing any performance attributes. There is no fear of any acid spillage as ODYSSEY recycles the internal gas during operation or charging. The sealed design of the ODYSSEY battery eliminates the need for an acid vent tube; eliminating the fear of acid burns or damage to expensive chrome or paint.

SUPERIOR VIBRATION RESISTANCE

ODYSSEY batteries are of military grade and have endured rigorous tests that demonstrate their overall ruggedness and exceptional tolerance of mechanical abuse.

READY OUT OF THE BOX

ODYSSEY batteries are shipped fully charged. If ODYSSEY'S voltage is 12.65V or greater simply install the battery in your vehicle and you are ready to go! If below 12.65V, boost charge following the instructions in the ODYSSEY Owner's Manual and/or Technical Manual. Putting a boost on the battery will not hurt it, even if its voltage reads higher than 12.65V.

WORRY-FREE SHIPPING

Owing to the drycell design, the US Department of Transportation (USDOT) has classified the ODYSSEY battery as a nonspillable, so it may be shipped worry-free by express service or by air.

LONGER STORAGE LIFE

Unlike conventional batteries that need to be recharged every six to twelve weeks the ODYSSEY battery, when fully charged, can be stored for up to 2 years at 25°C (77°F). Simply recharge and ODYSSEY is returned to full power. At lower temperatures, storage times will be even longer.

DEEP DISCHARGE RECOVERY

Should ODYSSEY become deeply discharged, simply recharge following instructions in the ODYSSEY Owners Manual.

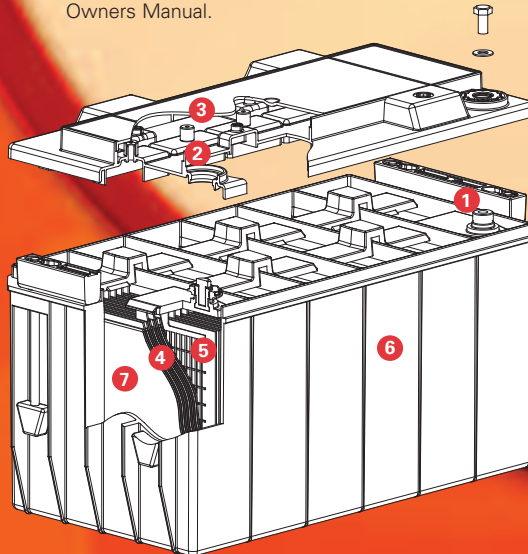

CONSTRUCTION

- 1 High Conductivity terminals
- 2 High integrity terminal seal
- 3 Self-regulating relief valve
- 4 Rugged high performance positive plates
- 5 Balanced negative plates
- 6 Tough flame retardant cell containers (flame retardant material not applicable to PC535, PC625 and PC2150 models)
- 7 Glass mat separators

ODYSSEY PROVIDES THE POWER FOR EVERY PURPOSE

MODEL	Voltage	PHCA** (5 Sec)	CCA*	HCA	MCA	Nominal Capacity		Reserve Capacity Minutes	Length inches (mm)	Width inches (mm)	Height inches (mm)	Weight lbs (kg)	Terminal	Torque Specs in-lbs (Nm max)	Internal Resistance (mΩ)	Short Circuit Current
						(20 Hr Rate - Ah)	(10 Hr Rate - Ah)									
PC310	12	310	100	200	155	8	7	9	5.43 (138.0)	3.39 (86.0)	3.98 (101.0)	5.9 (2.7)	M4 Bolt	8.9 (1.0)	27.1	455A
PC535	12	535	200	300	265	14.8	13	21	6.70 (170.2)	3.90 (99.1)	6.125 (155.6)	12.0 (5.4)	M6 Bolt	40 (4.5)	8	1000A
PC545	12	545	185	300	240	14	12	18	7.00 (177.8)	3.37 (85.6)	5.17 (131.3)	12.6 (5.7)	M6 Bolt†	50 (5.6)	10	1200A
PC625	12	625	265	440	350	18	17	27	6.70 (170.2)	3.90 (99.1)	6.89 (175.0)	13.2 (6.0)	M6 Stud	40 (4.5)	7	1800A
PC680	12	680	220	370	300	17	16	24	7.27 (184.7)	3.11 (79.0)	6.67 (169.4)	15.4 (7.0)	M6 Bolt† or SAE 3/8" Receptacle	50 (5.6)	7	1800A
PC925	12	925	380	625	500	28	27	52	6.64 (168.6)	7.05 (179.0)	5.04 (128.0)	26.0 (11.8)	M6 Bolt† or SAE 3/8" Receptacle	60 (6.8)	5	2400A
PC1200	12	1200	550	860	725	44	40	78	7.87 (199.9)	6.66 (169.1)	6.80 (172.7)	38.2 (17.4)	M6 Bolt† or SAE 3/8" Receptacle	60 (6.8)	4.5	2600A
PC1500	12	1500	825	1250	1050	68	62	125	10.85 (275.6)	6.99 (177.5)	7.82 (198.6)	53.0 (24.0)	TOP SAE 3/8" Receptacle SIDE 3/8" 16 Threaded Nut	60 (6.8)	2.5	3100A
PC1700	12	1700	875	1325	1175	68	65	142	13.02 (330.7)	6.62 (168.2)	6.93 (176.0)	60.9 (27.6)	M6 Bolt,† SS 5/16" Stud or SAE 3/8" Receptacle	60 (6.8)	3.5	3500A
PC2150	12	2150	1090	1545	1370	100	92	200	13.00 (330.2)	6.80 (172.7)	9.41 (239.0)	75.0 (34.1)	3/8" Stud/ SAE	150-200 (16.9-22.6)	2.2	5000A
PC2250	12	2250	1225	1730	1550	126	114	240	11.26 (286.0)	10.59 (269.0)	9.17 (233.0)	86.0 (39.0)	Dual SAE/DIN Terminal and 3/8" Stud	100 (11.0) For 3/8" Stud only	2.1	5000A

* Cold Start Performance S.A.E J537 JUNE 82 **Pulse Current † Can be fitted with brass automotive terminal

All batteries available with metal jackets, except PC310, PC535, PC625, PC1500 and PC2250

Operating temperature range: -40°C (-40°F) to 45°C (113°F) • -30°C (-22°F) to 40°C (104°F) for PC2250 • -40°C (-40°F) to 80°C (176°F) with metal jackets on all other sizes

TERMINAL LAYOUTS

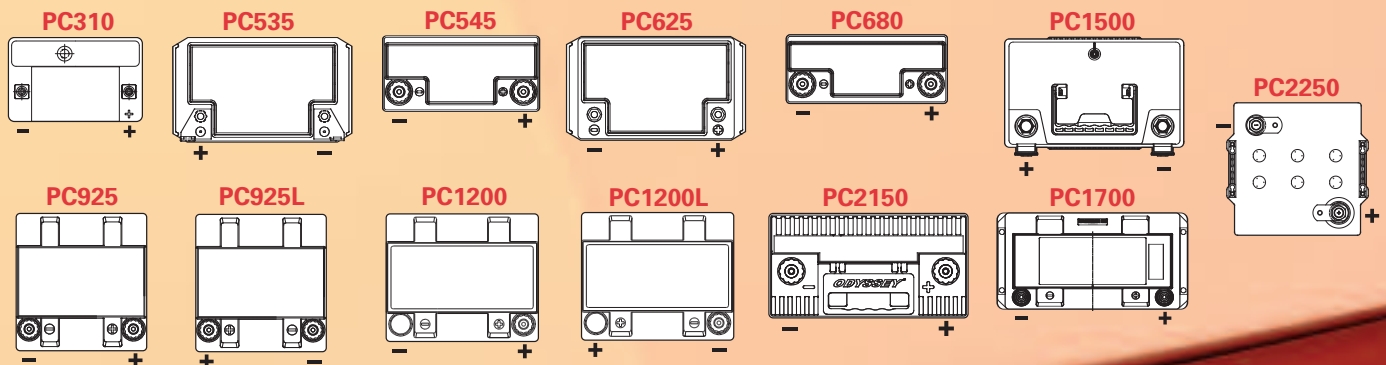

Drawing sizes are for terminal position reference only; diagrams are not proportionate to each other.

ODYSSEY™

THE EXTREME BATTERY

ODYSSEY TECHNOLOGY COMPARISON

	ODYSSEY	CONVENTIONAL
DESIGN LIFE	8-12 years (Float) @ 25°C (77°F)	5 years
SERVICE LIFE	3 to 10 years	1 to 5 years
ELECTROLYTE	Drycell ("starved electrolyte") no external leakage or corrosion	Most are acid flooded (causing acid burns and spills); some wet sealed or "gelled"
STORAGE LIFE	2 years before needing charge @ 25°C (77°F)	6-12 weeks before needing charge
SHIPPING	Air transportable; classified non-spillable (less expensive)	Ground transport; classified as hazardous material (more expensive)
END OF LIFE	Battery slowly loses power at end of life; no catastrophic failure	Immediate and catastrophic loss of power (can leave you stranded)

EnerSys

P.O. Box 14145
Reading, PA 19612-4145, USA
Tel: +1-610-208-1991
+1-800-538-3627
Fax: +1-610-372-8613

Contact:

Regional Sales

EnerSys Energy Products Inc.
617 North Ridgeview Drive,
Warrensburg,
MO 64093-9301, USA
Tel: +1-660-429-2165
Fax: +1-660-429-1758

EnerSys Limited
Rake Lane,
Clifton Junction,
Manchester M27 8LR UK
Email: odyssey.sales@uk.enersys.com
Tel: +44 (0)161 727 3952
Fax: +44 (0)161 727 3805

EnerSys Australia Pty Ltd
7 Walker Place,
Wetherill Park, NSW,
Australia, 2164
Tel: + 61 (0) 29756 1870
Fax: + 61 (0) 29757 4537
Toll-free: 1-800-550-153

Website: www.odysseyfactory.com

© 2006 EnerSys. All rights reserved.
Trademarks and logos are the property of EnerSys and its affiliates unless otherwise noted.

Printed in USA

WARRANTY:

EnerSys Energy Products Inc. ("Manufacturer") warrants its ODYSSEY™ batteries to be free of defects in material and workmanship for the earlier of (a) the Applicable Warranty Period or (b) within 400 cycles to 80% depth of discharge, whichever occurs first. The Applicable Warranty Period is two (2) years for power sports applications; three (3) years in automotive, marine, commercial, and industrial applications; and, in the case of the PC2150 and PC2250 batteries, four (4) years in all applications from the date of purchase with original receipt, or, if no receipt is available, from Manufacturer's shipping date. Within the warranty period, the battery will be replaced free of charge if adjustment is necessary due to defect in material or workmanship (not merely discharged). Simply return the battery to any authorized ODYSSEY dealer with the original receipt for a replacement. This warranty may vary from country to country; contact your authorized ODYSSEY wholesaler or dealer for the applicable warranty.

GENERAL PROVISIONS

A. Manufacturer has no obligation under the limited warranty set forth above in the event the battery is damaged or destroyed as a result of one or more of the following:

- Willful abuse or neglect or if the top decorative cover has been removed.
- Natural forces such as wind, lightning, hail; damage due to fire, collision, explosion, vandalism, theft, penetration or opening of the battery case in any manner.
- Overcharging, undercharging, charging or installing in reverse polarity, improper maintenance, allowing the battery to be deeply discharged via a parasitic load or mishandling of the battery such as but not limited to using the terminals for lifting or carrying the battery.
- Failure to properly install the battery or lack of metal jacket for high temperature or vibration applications.
- Normal deterioration in the electrical qualities or the acceleration of such deterioration due to conditions that accelerate such deterioration.
- If the battery is used for an application that requires higher cranking power or a greater reserve rating than the battery is designed to deliver, or the battery capacity is less than the battery capacity specified by the vehicle manufacturer, or the battery is otherwise used in applications for which it was not designed.

B. To obtain warranty service:

1. Return the battery to any authorized ODYSSEY wholesaler or dealer.
2. If the battery is determined to be defective for material or workmanship under terms of this limited warranty, it will be replaced.

THIS LIMITED WARRANTY IS IN LIEU OF, AND MANUFACTURER DISCLAIMS AND EXCLUDES, ALL OTHER WARRANTIES, STATUTORY, EXPRESS OR IMPLIED, INCLUDING, WITHOUT LIMITATION, ANY WARRANTY OF MERCHANTABILITY OR FITNESS FOR A PARTICULAR PURPOSE. MANUFACTURER'S EXCLUSIVE LIABILITY FOR BREACH OF WARRANTY SHALL BE TO REPLACE THE BATTERY WITHIN THE EFFECTIVE WARRANTY PERIOD. IN NO EVENT SHALL MANUFACTURER BE LIABLE FOR ANY LOSS OR DAMAGES OF ANY OTHER KIND, WHETHER DIRECT, INCIDENTAL, CONSEQUENTIAL, EXEMPLARY, SPECIAL OR OTHERWISE. NOR SHALL MANUFACTURER BE LIABLE FOR ANY REMOVAL OR INSTALLATION EXPENSE, OR THE LOSS OF TIME OR PROFITS.

Some countries and/or states do not allow limitation on how long an implied warranty lasts or the exclusion or limitation of incidental or consequential damages, so the above limitations may not apply to you. This warranty gives you specific legal rights which may vary from country to country and/or state to state.

